

**24SI ALTERNATOR INSTRUCTIONS FOR REPLACING  
DELCO REMY 21SI, 22SI, 23SI AND 24SI ALTERNATORS**

**WARNING!!!** ALWAYS USE PROPER EYE PROTECTION WHEN PERFORMING ANY MECHANICAL REPAIRS TO A VEHICLE – INCLUDING, BUT NOT LIMITED TO, ANY INSTALLATION AND OR REPAIRS TO THE DELCO REMY ALTERNATORS. FAILURE TO USE PROPER EYE PROTECTION CAN LEAD TO SERIOUS AND PERMANENT EYE DAMAGE.

Only perform the mechanical functions that you are properly qualified to perform. A professional installation specialist should handle mechanical repairs that are beyond your technical capabilities.

**DANGER!!!** To avoid injury or damage, always disconnect the negative cable at the battery before removing or replacing the alternator. The alternator output terminal is always live (“hot”). If the battery is not disconnected, a tool accidentally touching this terminal and ground can quickly get hot enough to burn skin or damage to the tools and surrounding parts.

**FOLLOW ENGINE OR VEHICLE MANUFACTURER’S INSTRUCTIONS FOR REMOVING THE OLD ALTERNATOR FROM THE ENGINE AND INSTALLING THE NEW ALTERNATOR.**

**PULLEY INSTRUCTIONS:** Use pulley from old alternator if this alternator does not have a pulley or pulley supplied is different from the one on alternator being replaced. **NOTICE!** When changing the pulley, keep the alternator in the horizontal position and do not apply any pressure to end of the shaft. Internal damage will occur if the shaft is

pushed back and turned. If there were spacers, when the fan (21SI & 22SI) and pulley were removed, make sure all spacers are replaced when installing the pulley on the 24SI alternator. Hold the shaft by placing an 8.01 mm (5/16”) hex wrench in the hexagonal hole in the shaft while removing or installing the pulley. Tighten the pulley nut to 95-108 Nm (70-80 lb ft).

**FAN:** Do not install external fan from alternator being replaced. The 24SI alternators have dual internal cooling fans and do not require an external fan.

**NOTICE!** This alternator is designed for use in a **Clock-Wise (CW)** direction only if you are looking at pulley side (front) of alternator. Do not install on a **Counter-Clock-Wise (CCW)** application.

**BELT TENSIONING INSTRUCTIONS:** Improper belt tension can cause premature alternator failure. If the belt must be tightened manually, place a wood block between the alternator and pry bar (See illustration). Pry as close to the center of the unit as possible. Use a torque wrench to tighten mounting bolts to specified torque. Follow vehicle or engine manufacturer’s specifications carefully for belt tension and mounting bolts torque. **DO NOT OVER TIGHTEN BELT!**

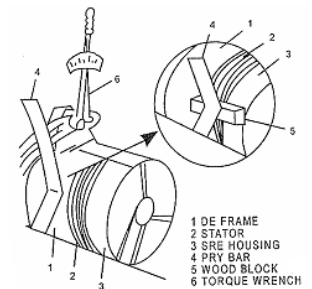

1 DE FRAME  
2 STATOR  
3 SRE HOUSING  
4 PRY BAR  
5 WOOD BLOCK  
6 TORQUE WRENCH

**INSTALLATION INSTRUCTIONS** (See illustrations, page 2):

- ◆ Disconnect the negative (-) cable at the batteries.
- ◆ Identify and tag all leads when removing the old Alternator and install them on the same terminals of the 24SI Alternator.
- ◆ Some 21SI and 22SI applications will require enlarging the ring terminals. Most will also require wiring modifications and use of the adaptor illustrated below.
- ◆ **Cut lead, strip insulation 1/4-3/8”, insert wire into appropriate colored terminal, crimp terminal and using a Heat Gun, apply heat to Heat Shrink tube until it forms and seals around lead.**
- ◆ Install the output (BAT) lead and torque nut to 6.2-7.9 Nm (55-70 lb in).
- ◆ Install the ground (GRD) lead and torque screw to 9.0-13.6 Nm (80-13.6 lb in).
- ◆ Plug and seat the regulator or adaptor connector into the alternator regulator connection.
- ◆ Ensure all leads are hooked back up or contained where they cannot ground.
- ◆ This 24SI may have more terminals than the alternator it is replacing had or used. It will function properly by only hooking up the leads that were used on the alternator being replaced.

**REPLACING A 21SI OR 22SI ALTERNATOR THAT HAS A 2-TERMINAL VOLTAGE REGULATOR**

- ◆ REPLACING THESE MODELS REQUIRES USING THIS WEATHER PACK CONVERSION ADAPTOR KIT

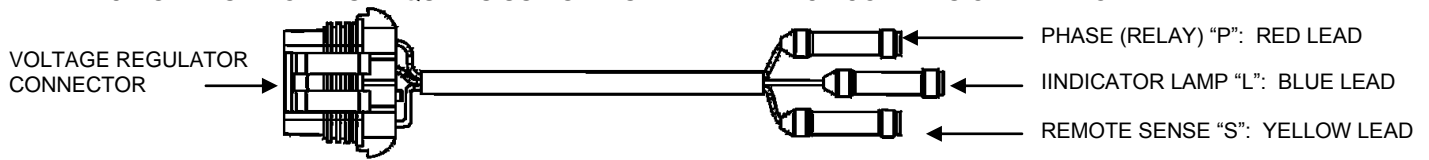

**Notice!** Do not install the Remote Sense™ line (# 2 Regular terminal on some 21SI & 22SI models) to the Relay (red lead).

**NOTICE** - Only licensed Remy International, Inc. product and component parts should be used, and the use of other parts or modifications not approved by Remy International, Inc. will void all applicable warranties. The failure to carefully follow these Installation Instructions, set forth above, will void all applicable warranties. DELCO REMY is a registered trademark of General Motors Corporation, licensed to Remy International, Inc. Pendleton, IN 46064.

**DESCRIPTIONS OF ALTERNATOR TERMINALS (See illustrations):**

**“BAT” Output (+)** - Output terminal, connects to the Positive (BAT) Battery terminal to charge the batteries.

**“P” Phase (Relay)** - Relay terminal carries half system voltage and may be used for certain types of control relays, charge indicators, tachometers or similar devices. The current draw should not exceed four (4) amperes. **Notice!** Do not connect the remote sense lead to this terminal.

**“L” Indicator Lamp** - Indicator Lamp terminal can take up to 1 Amp Lamp Current.

**Field Monitor** - External Field Monitor is only used for diagnostics.

**“GRD” Screw** - Grounds the alternator. A Ground lead is strongly recommended for optimum performance.

**“Remote Sense™” Terminal** - Remote Voltage Sense (if equipped) used to more accurately control system voltage by monitoring actual voltage at Battery Terminal or Junction Block. **Notice!** Be careful not to ground the lead’s open end, because the line is always live “hot”.

**NOTICE! DO NOT INSTALL EXTERNAL FAN ON 24SI ALTERNATOR**

**USE PULLEY FROM OLD ALTERNATOR IF IN OPERABLE CONDITION (SEE PULLEY INSTRUCTIONS)**

OUTPUT TERMINAL (+)  
9.0-13.0 Nm (80-120 lb in)

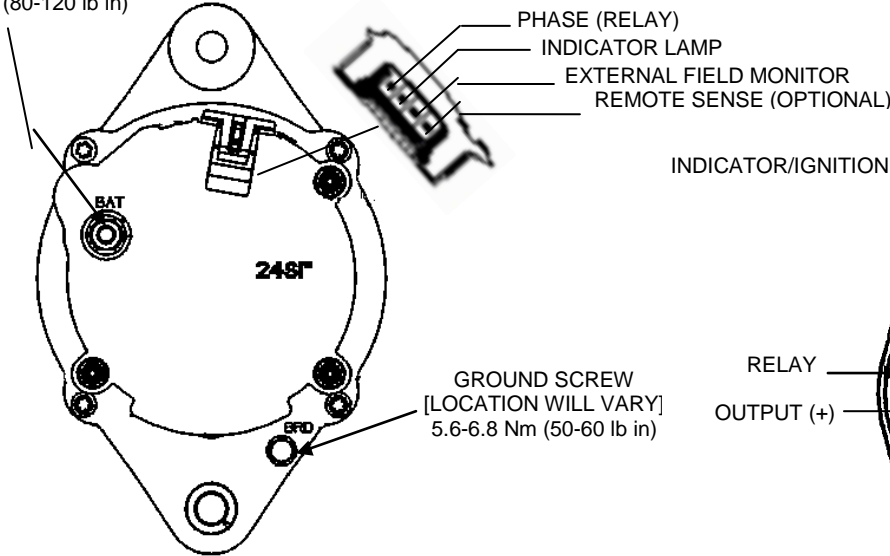

**24SI ALTERNATOR**

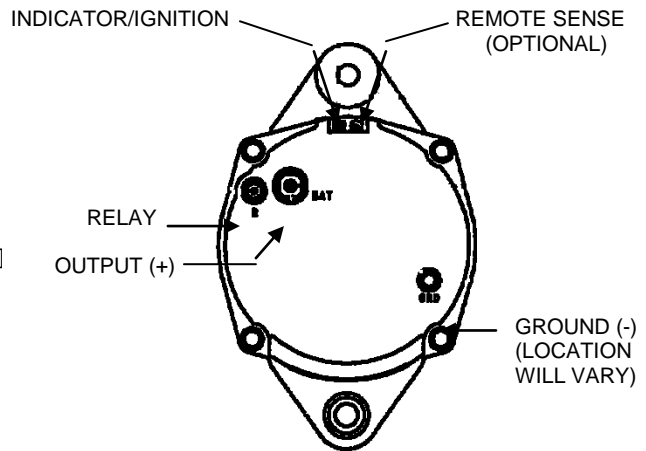

**21SI & 22SI REMOTE SENSE 2-TERMINAL REGULATOR**

**NOTICE! USE ON Clock-Wise APPLICATIONS ONLY (viewing pulley side of alternator)**

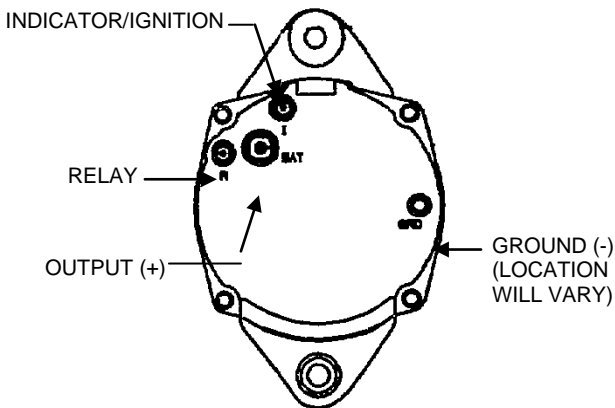

**21SI, 22SI & 23SI NON-REMOTE SENSE  
(23SI TERMINAL LOCATIONS VARY)**

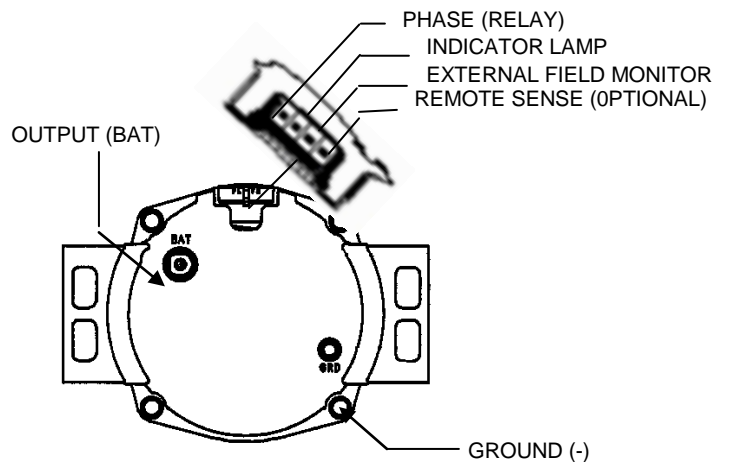

**22SI REMOTE SENSE  
4-TERMINAL REGULATOR**

**Technical support: USA 800 854 0076, Mexico 01 800 000 7378, Brazil 0800 703 3526, South America 55 11 2106 6510 or visit [delcoremy.com](http://delcoremy.com)**

**NOTICE** - Only licensed Remy International, Inc. product and component parts should be used, and the use of other parts or modifications not approved by Remy International, Inc. will void all applicable warranties. The failure to carefully follow these Installation Instructions, set forth above, will void all applicable warranties. DELCO REMY is a registered trademark of General Motors Corporation, licensed to Remy International, Inc. Pendleton, IN 46064.

© 2012 Remy International, Inc. All rights reserved