

**REASSEMBLING OF CS-144 GENERATOR**

**WARNING!!!** ALWAYS USE PROPER EYE PROTECTION WHEN PERFORMING ANY MECHANICAL REPAIRS TO A VEHICLE – INCLUDING, BUT NOT LIMITED TO, ANY INSTALLATION AND OR REPAIRS TO THE DELCO REMY ALTERNATOR. FAILURE TO USE PROPER EYE PROTECTION CAN LEAD TO SERIOUS AND PERMANENT EYE DAMAGE.

Only perform the mechanical functions that you are properly qualified to perform. Mechanical repairs that are beyond your technical capabilities should be handled by a professional installation specialist.

**DANGER!!!** To avoid injury or damage, always disconnect the negative cable at the battery before removing or replacing the alternator. The alternator output terminal is always live (“hot”). If the battery is not disconnected, a tool accidentally touching this terminal and ground can quickly get hot enough to cause skin burn or damage to the tool and surrounding parts.

**REASSEMBLY OF ROTOR AND DRIVE END FRAME (including bearings) [See Figure 1]**

Note stack-up of parts for drive end (D.E.) frame reassembly [Figure 1]. Press against outer race of D.E. bearing to assemble into D.E. frame. Bearing is sealed and requires no lubrication. Assemble other parts as shown [Figure 1]. Rotor may be held with hex wrench in end of shaft when tightening D.E. shaft nut on assembled alternator. Tighten nut to 100 Nm (75 lb ft).

**IMPORTANT!** A new slip ring end (S.R.E.) bearing must be installed every time the rotor is separated from the S.R.E. frame. To install the S.R.E. bearing on the shaft, press against the inner race of the bearing until it is against the stop on the shaft.

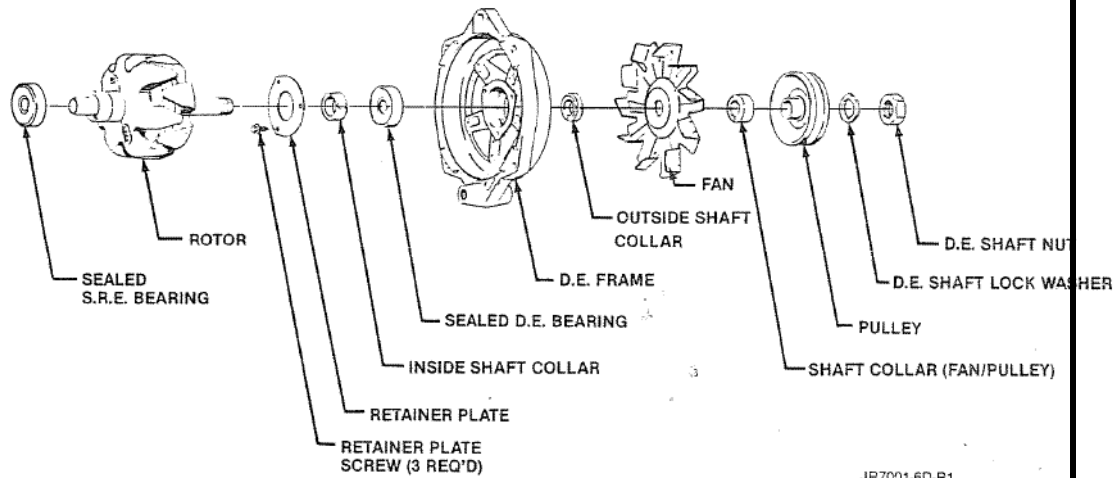

FIG. 1 — ROTOR AND DRIVE END ASSEMBLY

**BRUSH HOLDER INFORMATION [See Figure 2]**

**IMPORTANT!** A design change prevents early brush holders from being installed in later-design S.R.E. frames, unless the brush holder assembly is modified. To do this, use needle nose pliers or side cutters to break away the locators [Figure 2]. Use an ordinary file to smooth any jagged edges down to the level of the surrounding material. Avoid getting loose particles of the brush holder material into the brush slots. Vacuum or blow any dust away when the modification is complete.

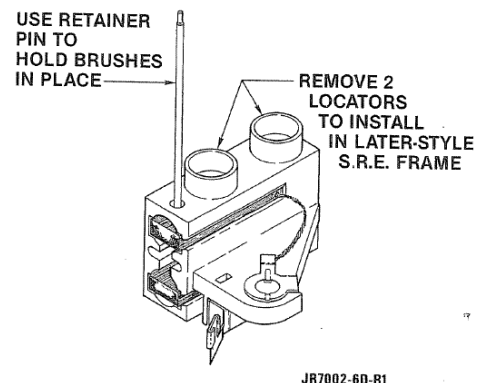

FIG. 2 EARLY STYLE BRUSH HOLDER

When installing a later-style brush holder assembly without locators into an older-style S.R.E. frame that has two round locator bosses, align the brush holder assembly and hold it with fingers while tightening the brush holder attaching screw. The lack of locators will not adversely affect operation of the unit once the brush holder assembly is properly installed.

## REASSEMBLY OF S.R.E. FRAME COMPONENTS [See Figure 3]

**IMPORTANT!** Install the rectifier bridge, capacitor, regulator, and brush holder into the S.R.E. frame as shown [Figure 3] **MUST** be done in the following order to assure proper operation of the unit. **Assembly in any other manner will result in either no output from the alternator or a direct internal ground in the alternator:**

1. Install rectifier bridge and capacitor. The capacitor strap has an insulator material on one side which must rest against the end frame (ground). Bolt the rectifier bridge and capacitor in place using three (3) rectifier bridge attaching screws. Assure that insulated screw is installed in proper hole [Figure 3].
2. Install regulator and brush holder (refer to brush holder information on previous page). Hold brushes in place with retaining pin. The metal side of the capacitor strap should be against the regulator connection. Install and tighten the insulated regulator attaching screw and the brush holder attaching screw (ground).
3. Install connection between regulator and bridge terminal. Crimp and solder the regulator connections for this connector and for the brush holder. Avoid excessive heat.
4. Install stator (not shown), placing leads over bridge terminals. Install and tighten three (3) rectifier bridge nuts.

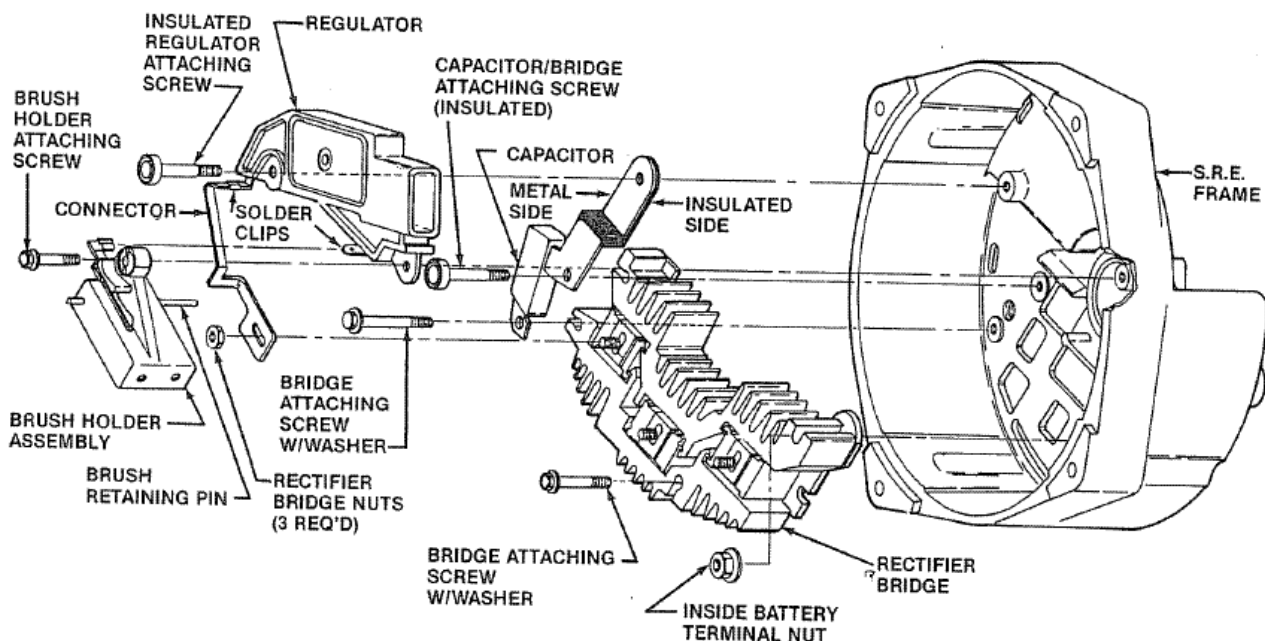

JR7003-6D-R1

FIG. 3. S.R.E. COMPONENT ASSEMBLY

## FINAL ASSEMBLY

Complete alternator assembly by mating S.R.E. and D.E. assemblies together. **CAREFULLY** guide the S.R.E. bearing outer race into the bearing well in the S.R.E. casting, assuring that the tolerance rings on the bearing outer race are not damaged. Install and tighten four (4) thru-bolts. Remove brush retainer pin to release brushes against slip rings.

Technical support: USA 800 854 0076, Mexico 01 800 000 7378, Brazil 0800 703 3526, South America 55 11 2106 6510 or visit [delcoremy.com](http://delcoremy.com)

**NOTICE** - Only licensed Remy International, Inc. product and component parts should be used, and the use of other parts or modifications not approved by Remy International, Inc. will void all applicable warranties. The failure to carefully follow these Installation Instructions, set forth above, will void all applicable warranties. DELCO REMY is a registered trademark of General Motors Corporation, licensed to Remy International, Inc. Pendleton, IN 46064.

© 2012 Remy International, Inc. All rights reserved