

## REPLACING 25SI REGULATOR

**WARNING!!!** ALWAYS USE PROPER EYE PROTECTION WHEN PERFORMING ANY MECHANICAL REPAIRS TO A VEHICLE – INCLUDING, BUT NOT LIMITED TO, ANY INSTALLATION AND OR REPAIRS TO THE DELCO REMY ALTERNATOR. FAILURE TO USE PROPER EYE PROTECTION CAN LEAD TO SERIOUS AND PERMANENT EYE DAMAGE.

Only perform the mechanical functions that you are properly qualified to perform. Mechanical repairs that are beyond your technical capabilities should be handled by a professional installation specialist.

**DANGER!!!** To avoid injury or damage, always disconnect the negative cable at the battery before removing or replacing the alternator. The alternator output terminal is always live ("hot"). If the battery is not disconnected, a tool accidentally touching this terminal and ground can quickly get hot enough to cause skin burn or damage to the tool and surrounding parts.

The integrated circuit (IC) voltage regulator, base plate, diode trio, and attaching hardware in this package are used to replace discrete component regulators used in earlier designs of 25SI alternators. The earlier regulators have separate transistors, diodes and other components mounted on a circuit board covered with an RTV-type coating. Both the new diode trio and the new regulator must be installed to replace this old type of regulator. New mounting holes must be drilled into the alternator housing to attach the new components. Use the procedure in this instruction sheet to replace the earlier design discrete component regulator.

In addition to the items supplied in the package and the usual hand tools, a drill with 9/64 inch diameter bit will be needed to complete the installation.

### Install regulator and diode trio as follows:

1. Remove four thru-bolts from alternator and separate drive end assembly (with rotor) from rectifier end assembly. This is necessary to allow complete removal of metal shavings created by drilling holes. Cover the open end of the rectifier end bearing with tape to keep shavings from getting into the bearing grease.

2. Remove end plate and rectifier cover from rectifier end assembly by removing attaching screws.

3. Remove nuts from rectifier bridge terminals and inside of "R" terminal to disconnect three long, identically colored leads to regulator. Some units may have a separate lead between the "R" terminal and a rectifier bridge terminal - if so, remove this lead also. Place nuts loosely back on "R" terminal and on rectifier bridge terminals to hold other leads in place during repair. If old regulator has a sense lead connected to the heat sink attaching screw (see **Fig. 2** for location), remove screw, flat washer and insulator to disconnect lead. Place insulator, washer, and heat sink screw loosely back into unit for later attachment of new sense lead. Disconnect two field coil leads from regulator and remove two regulator-mounting screws. Lift regulator and long leads with grommet from generator housing.

4. **See Fig. 1.** Place new diode trio and regulator base plate in position as shown. Locate base plate by positioning mounting hole A over existing mounting hole in casting. Temporarily install the 1/2" long mounting screw in hole A to hold plate, aligning edges to be straight with sides of casting. Mark 3 new hole locations (C, D and E), then remove diode trio and base plate from housing. Use 9/64" drill bit to make new mounting holes in housing. Holes C and E will go through housing wall. Hole D is positioned in thicker cross section and will not go through – drill 3/4" deep, straight into housing material. Remove all traces of metal shavings from both inside and outside of housing when drilling is complete.

5. **See Figs. 1 & 2.** Place diode trio into position in housing. Coat threads on 1/2 inch long screw (in package), with high temperature adhesive/sealant (Loctite® 620, in package). Secure diode trio to housing with screw at mounting hole E. Tighten screw in newly drilled mounting hole to 3.4 Nm (30 lb in). Note: When reinstalling screw in hole previously used, tighten to 3.0 Nm (26 lb in). This is a grounding screw and must be secure.

6. **See Fig. 2.** Locate heat sink attaching screw for connecting red diode trio lead. Remove screw, flat washer, and insulator. Place connector of red lead over hole, then reinstall insulator, flat washer and screw. Connector of red lead must be under insulator. Tighten screw to 3.0 Nm (26 lb in).

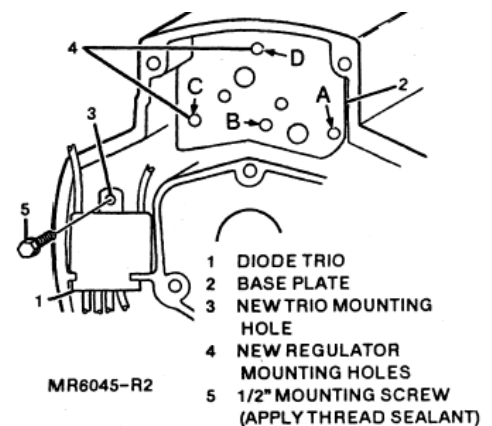
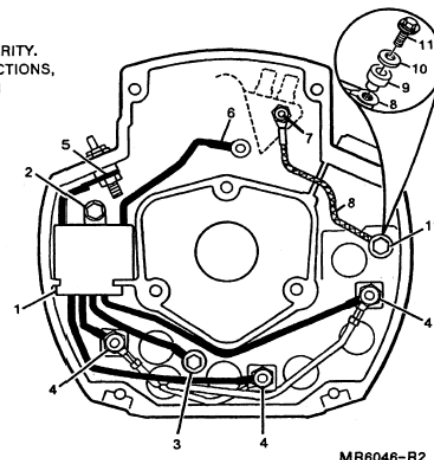

**FIG. 1** LOCATING NEW MOUNTING HOLES AND INSTALLING DIODE TRIO

7. **See Fig. 2.** Locate three yellow leads coming out of diode trio on same side as red lead. Connect each lead to a different rectifier bridge terminal, using three nuts removed and left loosened earlier. Be sure all leads to each of these terminals are properly reconnected. Tighten nuts to 3.0 Nm (26 lb in).
8. Install remaining yellow lead coming out of diode trio (on same side as blue lead) to inside of "R" terminal with existing attaching nut (**Fig 2**). It may be necessary to hold hex shoulder on outside of terminal as anti-turn while tightening nut. Tighten nut to 2.3 Nm (20 lb in). Be sure terminal lead does not touch housing after tightening.
9. **See Fig. 3.** Coat back (metal side) of new regulator with silicone dielectric grease (Loctite® 5840, in package). Place regulator onto base plate, aligning 3 mounting holes (B, C, D) in each. Position blue lead from diode trio and one field coil lead over mounting hole B (see illustration), then insert 1 inch long

**NOTE:** SOME INTERNAL WIRING IS OMITTED FROM ILLUSTRATION FOR CLARITY. UNLESS NOTED OTHERWISE IN INSTRUCTIONS, REINSTALL ALL OTHER WIRES TO THEIR ORIGINAL LOCATIONS.

- 1 DIODE TRIO
- 2 DIODE TRIO MOUNTING SCREW
- 3 HEAT SINK ATTACHING SCREW FOR DIODE TRIO LEAD
- 4 RECTIFIER BRIDGE TERMINALS (3 PLACES)
- 5 INSIDE "R" TERMINAL CONNECTION
- 6 TRIO LEAD TO REGULATOR (STEP 9)
- 7 REGULATOR STUD (STEP 14)
- 8 SENSE LEAD (STEP 14)
- 9 INSULATOR
- 10 PLAIN WASHER
- 11 HEAT SINK ATTACHING SCREW FOR SENSE LEAD



MR6046-R2

FIG. 2 DIODE TRIO AND SENSE LEAD CONNECTIONS

insulated screw through regulator and base plate. Install nut/lockwasher assembly. Be sure the 3 regulator and base plate mounting holes are still aligned. Hold screw at hex cap and tighten nut to 3.0 Nm (26 lb in).

10. **See Fig. 4.** Coat areas on back of base plate (side away from regulator) that will touch rectifier housing with silicone dielectric grease (Loctite® 5840, in package). Coat ends of spacer with same grease, then place spacer over newly drilled mounting hole C. Place regulator/plate assembly into housing and align to mounting holes. Blade terminals on regulator **MUST NOT** touch alternator housing – trim ends of terminals if necessary to avoid contact. Install 1/2 inch long screw (provided in package) to hole A in base plate and old mounting hole in housing (finger tighten).

11. **See Fig. 4.** Insert 2 inch long insulated screw (in package) through remaining field coil lead then coat threads with high temperature adhesive/sealant (Loctite® 620, in package). Without getting sealant on surface of regulator contact, insert screw through regulator, base plate, and spacer into newly drilled mounting hole C (finger tighten).

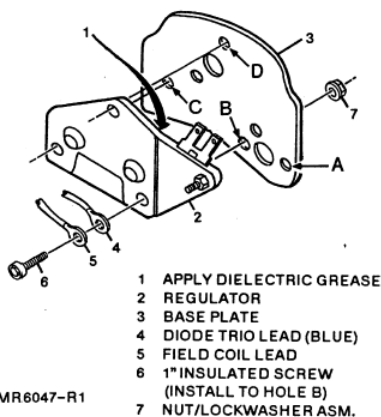

MR6047-R1

FIG. 3 ATTACHING REGULATOR TO BASE PLATE

12. **See Fig. 4.** Install 1 inch long screw (provided in package) through regulator and base plate, and into newly drilled mounting hole D.
13. Tighten screw in existing mounting hole A to 3.0 Nm (26 lb in). Tighten screws in newly drilled mounting holes C and D to 3.4 Nm (30 lb in). The screw in hole D is a grounding screw - be sure regulator is held securely. **Note:** When reinstalling screws in previously used mounting holes C and D, tighten to 3.0 Nm (26 lb in).
14. **See Fig. 2.** Install yellow sense lead loosely to threaded stud on regulator with nut/lockwasher assembly, routing lead through grommet to heat sink attaching screw. Remove heat sink screw, plain washer, and insulator. Place sense lead connector over hole and reinstall insulator, washer, and screw. Sense lead must be under insulator. Tighten heat sink screw to 3.0 Nm (26 lb in).
15. Place rectifier cover back onto rectifier end assembly and reinstall attaching screws. Tighten screws to 5.3 Nm (47 lb in).
16. Install end plate to rectifier end assembly and reinstall attaching screws. Tighten screws to 3.0 Nm (26 lb in).
17. Check inside of rectifier and assembly for new metal shavings that may have been created by installation of self-tapping screws into newly drilled mounting holes. Remove all traces of metal shavings.
18. Remove protective tape from open end of bearing in rectifier end assembly. Assemble drive-end assembly (with rotor) to rectifier end assembly. Install thru-bolts and tighten to 6.0 Nm (55 lb in).

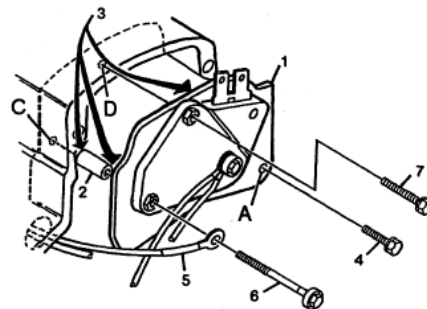

- 1 REGULATOR/PLATE ASM.
- 2 SPACER
- 3 APPLY DIELECTRIC GREASE
- 4 1/2" MOUNTING SCREW (INSTALL TO HOLE A)
- 5 FIELD COIL LEAD
- 6 2" INSULATED SCREW (APPLY THREAD SEALANT, INSTALL TO HOLE C)
- 7 1" MOUNTING SCREW (INSTALL TO HOLE D)

MR6048-R2

FIG. 4 INSTALLING REGULATOR/BASE PLATE ASM.

**Technical support: USA 800 854 0076, Mexico 01 800 000 7378, Brazil 0800 703 3526, South America 55 11 2106 6510 or visit [delcoremy.com](http://delcoremy.com)**

**NOTICE** - Only licensed Remy International, Inc. product and component parts should be used, and the use of other parts or modifications not approved by Remy International, Inc. will void all applicable warranties. The failure to carefully follow these Installation Instructions, set forth above, will void all applicable warranties. DELCO REMY is a registered trademark of General Motors Corporation, licensed to Remy International, Inc. Pendleton, IN 46064.

© 2012 Remy International, Inc. All rights reserved