

21SI™ & 22SI™ HD ALTERNATOR REPLACEMENT COMPONENTS INSTRUCTIONS

These instructions explain how to remove and replace serviceable components for these alternators.

WARNING!!! ALWAYS USE PROPER EYE PROTECTION WHEN PERFORMING ANY MECHANICAL REPAIRS TO A VEHICLE – INCLUDING, BUT NOT LIMITED TO, ANY INSTALLATION AND OR REPAIRS TO THE DELCO REMY® ALTERNATORS. FAILURE TO USE PROPER EYEPROTECTION CAN LEAD TO SERIOUS AND PERMANENT EYE DAMAGE.

Only perform the mechanical functions that you are properly qualified to perform. Mechanical repairs that are beyond your technical capabilities should be handled by a professional installation specialist.

DANGER!!! To avoid injury or damage, always disconnect the negative cable at the battery before removing or replacing the alternator. The alternator output terminal is always live (“hot”). If the battery is not disconnected, a tool accidentally touching this terminal and ground can quickly get hot enough to burn skin or damage tools and surrounding parts.

FOLLOW ENGINE OR VEHICLE MANUFACTURERS INSTRUCTION’S CAREFULLY WHEN REMOVING AND REINSTALLING THE ALTERNATOR.

- ◆ Disconnect the negative (-) cable at the batteries.
- ◆ Remove vehicle leads connected to the alternator, noting their positions for reinstallation of the alternator.

DIASSEMBLY INSTRUCTIONS FOR DRIVE END (DE) FRAME COMPONENTS - FAN - ROTOR - DE FRAME (WITH BEARING) - DE BEARING - BEARING RETAINER

REFERENCE: There is an exploded parts view of these alternators for easy reference on page 3. Exploded views can be found on the www.delcoremy.com web site under product support for these alternators and other products.

NOTE: Some components can be removed without following all steps as sequenced.

1. Remove the **pulley nut, pulley** and **fan**. If replacing one of these parts, dispose of it and install replacement. Torque the pulley nut to **95-108 Nm (70-80 lb ft)**.

NOTICE! Excessive movement of stator may weaken or break a lead or leads between the stator and rectifier assemblies.

2. If replacing the **rotor, DE frame, DE bearing** or **retainer plate**, remove the DE frame and rotor assembly, by removing the four (4) thru-bolts (mark end frames for reassembly) that hold the end frames together.
3. Separate the **rotor assembly** from the DE frame, using a press. If replacing rotor, dispose of it and press replacement rotor with spacer into DE frame.

NOTICE!!! It is recommended the DE and SRE bearings be replaced when replacing the rotor assembly.

4. If replacing **DE frame** (with bearing), dispose of it and press rotor assembly and spacer into replacement DE frame (with bearing).
5. If replacing **DE bearing**, remove the three (3) retainer plate screw assemblies and retainer plate. Using a press, remove and dispose of the old bearing and press new bearing into frame bore until seated, by applying **force against the outer race only**.
6. Reinstall or replace the bearing retainer plate and screws. Torque the three (3) retainer screws to **4.5 - 5.7 Nm (40 - 50 lb in)**.
7. Go to component assembly instructions, page 2.

DIASSEMBLY INSTRUCTIONS FOR SRE FRAME COMPONENTS - STATOR - TERMINAL PACKAGES - DIODE TRIO OR DIODE TRIO & AUTO START - REGULATOR – RECTIFIER BRIDGE – STATOR - SRE FRAME

REFERENCE: There is an exploded parts view of these alternators for easy reference on page 3. Exploded views can be found on the www.delcoremy.com web site under product support for these alternators and other products.

21S & 22SI VOLTAGE REGULATOR

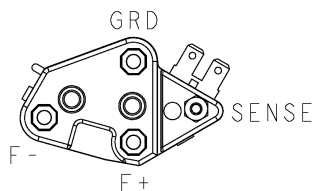

21SI & 22SI RECTIFIER BRIDGE

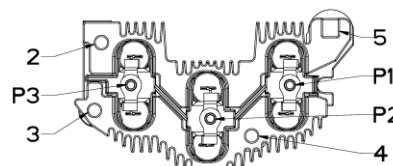

The regulator and rectifier terminals are labeled to better enable following instructions for replacing components and parts.

NOTE: Some components can be removed without following all steps as sequenced.

1. Remove the DE frame and rotor assembly, by removing the four (4) thru-bolts (mark end frames for reassembly) that hold the end frames together and separate the end frames.
2. If replacing the **stator**, remove the three (3) nut assemblies from the P1, P2 and P3 rectifier terminals, noting position of leads for reassembly. Install replacement stator, making sure leads are all the way down on the terminals, and three (3) nut assemblies. Torque nuts to **1.7-2.8 Nm (15-25 lb in)**.

NOTICE - Only licensed Remy International, Inc. product and component parts should be used, and the use of other parts or modifications not approved by Remy International, Inc. will void all applicable warranties. The failure to carefully follow these Installation Instructions, set forth above, will void all applicable warranties. DELCO REMY is a registered trademark of General Motors Corporation, licensed to Remy International, Inc. Pendleton, IN 46064.

3. If replacing the **SRE bearing** or **brush holder assembly**, remove brush holder assembly, washer and any other parts that could be damaged by pushing the bearing out with a press.
4. Push the bearing out, with a press, from the back of frame (closed end of bearing) inward and install replacement bearing. See graphic on page 3 for correct dimensional location of bearing in the frame.

WARNING!!! MULTIPLE STYLES OF SCREW ASSEMBLIES ARE USED, INCLUDING INSULATED AND NON-INSULATED, FOR REGULATORS AND RECTIFIER BRIDGES. THE SCREW ASSEMBLIES **MUST BE REPLACED IN THE SAME LOCATION** AS REMOVED TO AVOID GROUNDING OR OTHER UNDESIREABLE RESULTS.

5. If replacing terminal assemblies, it is advisable replace them one at a time, carefully noting parts and stack up and where leads are connected. Torque requirements for the "R", "I" & "sense" terminal nuts are **1.7 - 2.8 Nm (15 - 20 lb in)**. The output (B+) terminal torques are as follows: **1/4"** is **5.7 - 6.8 Nm (50 - 60 lb in)**, **M6** is **6.8 - 9.0 Nm (60 - 80 lb in)**, **5/16"** is **7.4 - 11.1 Nm (65 - 98 lb in)**. All terminals are insulated from the SRE frame.

DANGER!!! If all terminals are not kept insulated from the frame when the battery is connected, they can quickly get hot enough to burn skin and damage surrounding parts.

6. Remove **brush holder assembly** by first pushing brushes back, placing a pin through holes in brush holder and brushes to keep them in place, and removing the three (3) mounting screw assemblies, noting positions of the insulated screws.
7. Install brush holder assembly, three (3) mounting screws and torque to **1.7 - 2.8 Nm (15 - 20 lb in)**. The two (2) insulated screws also serve as regulator mounting screws.
8. Install a pin through holes in the SRE frame and brushes to allow for installation of the rotor. Remove pin after reassembly of the alternator.
9. If replacing the **regulator**, remove the nut, loosen the "B+" terminal nut and remove the three (3) screw assemblies, carefully noting where leads and/or straps are connected. The connections are as follows: "**F-**" -The terminal is connected to field coil at brush holder with an insulated screw. "**GRD**" -Nothing is connected. "**F+**" -The "I" and diode trio straps are connected with an insulated screw. "**Sense**" -The strap from the #5 rectifier bridge position is connected.
10. Install new regulator and reconnect leads and straps as removed. Install and torque the three (3) screw assemblies to **1.8 - 2.3 Nm (16 - 20 lb in)** and the nut assembly to **1.7 - 2.8 Nm (15 - 25 lb in)**.
11. If replacing the **diode trio** or diode trio & autostart, remove nut assemblies from P1 terminal, loosen the "R" terminal strap, P2, & P3 rectifier terminals, noting how the three (3) stator leads connect to the "P" terminals. If replacing **diode trio & autostart**, continue to remove screws from #2 (insulated) and #3 rectifier positions.
12. Install the replacement diode trio or autostart, screws in #2 (insulated) and #3 rectifier positions, "R" terminal strap and stator leads, insuring leads are all the way down. Reinstall the three (3) phase terminal nut assemblies and torque to **1.7 - 2.8 Nm (15 - 25 lb in)**. Install and torque the insulated screw, that connects the "I" terminal and trio straps to the "F+" regulator terminal, to **2.5 - 3.4 Nm (22 - 30 lb in)**. Tighten the "I" terminal nut to **1.7 - 2.8 Nm (15 - 25 lb in)** and output terminal nut according to size. See values in line 5 for correct torque. If autostart, install and torque the #2 position insulated screw and #3 position screw to **2.5 - 3.4 Nm (22 - 30 lb in)**.
13. If replacing **rectifier bridge**, remove the diode trio or diode trio & autostart plus the remaining screw from #4 position.
14. Install rectifier bridge assembly and replace all straps and connectors as removed. See above steps for terminations and torque values.

COMPONENT ASSEMBLY INSTRUCTIONS

1. Assemble the DE frame and rotor assembly with the SRE frame assembly, being sure to line up the non-threaded mounting lugs or marks. This is best accomplished by inserting a tolerance pin in the non-threaded holes on hinge mount (J180) units or two (2) parallel blocks with pad mount units.
2. Install the four (4) thru bolts and torque to 50% of final value. Use a staggered sequence to finish and torque thru-bolts to **10.7 - 11.9 Nm (95 - 105 lb)**.
3. Install external fan, pulley and pulley nut. Torque pulley nut to **95-108 Nm (70-80 lb ft)**.

REINSTALL THE ALTERNATOR ACCORDING TO ENGINE OR VEHICLE MANUFACTURERS INSTRUCTION'S

- ♦ Reattach the battery (+) terminal lead to alternator battery terminal and torque nut to **9.0-13.0 Nm (80 - 120 lb in)**.
- ♦ Reconnect the negative (-) cable at the battery.

Technical support: USA 800 854 0076, Mexico 01 800 000 7378, Brazil 0800 703 3526, South America 55 11 2106 6510 or visit www.delcoremy.com

21SI™ & 22SI™ SERVICE PARTS

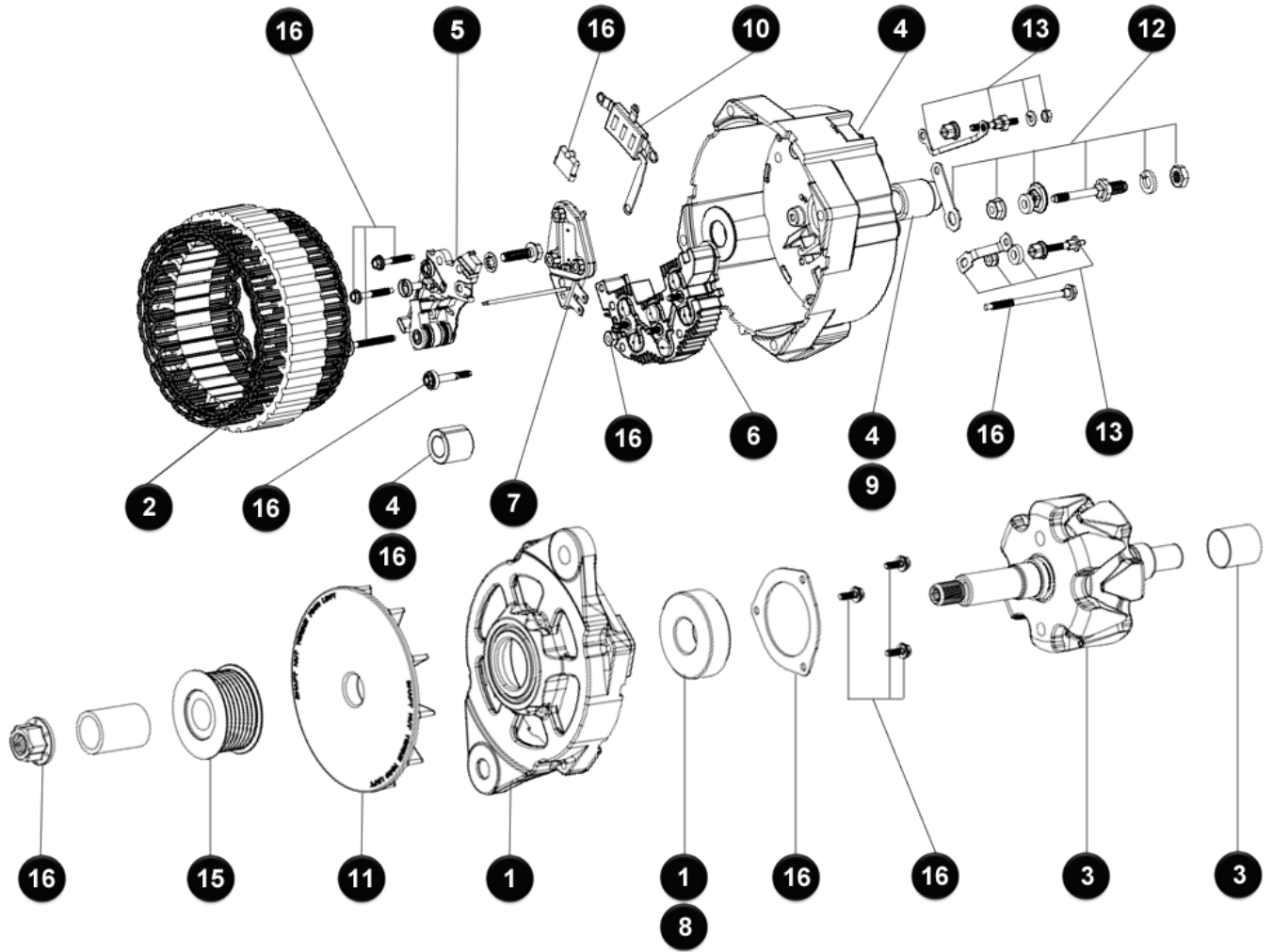

EXPLODED PARTS VIEWS OF 21SI & 22SI ALTERNATORS AND OTHER PRODUCTS ARE AVAILABLE ON THE www.delcoremy.com WEB SITE UNDER PRODUCTS AND SERVICE PARTS

21SI & 22SI SERVICE PACKGES

1. DE FRAME W / Bearing
2. STATOR ASM
3. ROTOR ASM
4. SRE FRAME W / BEARING
5. BRUSH HOLDER ASM
6. RECTIFIER BRIDGE
7. REGULATOR
8. BALL BEARING ASM
9. ROLLER BEARING ASM
10. DIODE TRIO OR DIODE TRIO & AUTOSTART
11. FAN
12. "B+" TERMINAL KIT
13. "I" TERMINAL KIT
14. "R" TERMINAL KIT
15. PULLY
16. RETAINER & HARDWARE

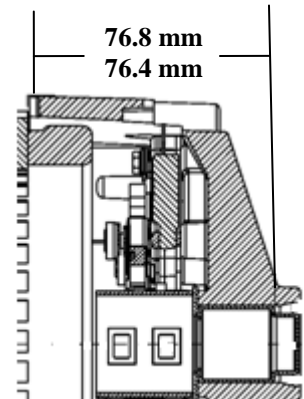

SRE BEARING LOCATION

Technical support: USA 800 854 0076, Mexico 01 800 000 7378, Brazil 0800 703 3526, South America 55 11 2106 6510 or visit www.delcoremy.com

NOTICE - Only licensed Remy International, Inc. product and component parts should be used, and the use of other parts or modifications not approved by Remy International, Inc. will void all applicable warranties. The failure to carefully follow these Installation Instructions, set forth above, will void all applicable warranties. DELCO REMY is a registered trademark of General Motors Corporation, licensed to Remy International, Inc. Pendleton, IN 46064. © 2012 Remy International, Inc. All rights reserved