

33SI™, 34SI™, 35SI™ & 36SI™ HD ALTERNATOR REPLACEMENT COMPONENTS INSTRUCTIONS

These instructions explain how to replace the serviceable components from these assemblies.

NOTE: It is beneficial and possibly necessary to obtain miscellaneous hardware packages for reassembly of these alternators. It is preferable to use new, undamaged parts.

WARNING!!! ALWAYS USE PROPER EYE PROTECTION WHEN PERFORMING ANY MECHANICAL REPAIRS TO A VEHICLE – INCLUDING, BUT NOT LIMITED TO, ANY INSTALLATION AND OR REPAIRS TO THE DELCO REMY® ALTERNATORS. FAILURE TO USE PROPER EYEPROTECTION CAN LEAD TO SERIOUS AND PERMANENT EYE DAMAGE.

Only perform the mechanical functions that you are properly qualified to perform. Mechanical repairs that are beyond your technical capabilities should be handled by a professional installation specialist.

DANGER!!! To avoid injury or damage, always disconnect the negative cable at the battery before removing or replacing the alternator. The alternator output terminal is always live (“hot”). If the battery is not disconnected, a tool accidentally touching this terminal and ground can quickly get hot enough to burn skin or damage tools and surrounding parts.

FOLLOW ENGINE OR VEHICLE MANUFACTURERS INSTRUCTION’S CAREFULLY WHEN REMOVING AND REINSTALLING THE ALTERNATOR.

- ◆ Disconnect the negative (-) cable at the batteries.
- ◆ Remove vehicle leads connected to the alternator, noting their positions for reinstallation of the alternator.

REMOVAL AND INSTALLATION INSTRUCTIONS FOR FAN - ROTOR - DE FRAME (WITH BEARING) - RE BEARING - DE BEARING - BEARING RETAINER

REFERENCE: There is an exploded parts view of these alternators for easy reference on page 3. Exploded views can usually be found on the www.delcoremy.com web site with the service list for these alternators other products.

1. Remove the pulley nut, pulley and fan. If replacing the **fan**, dispose of it and go to installation step 5.

NOTICE! Excessive movement may weaken or break a lead or leads between the stator and rectifier assemblies.

2. If replacing the rotor, DE frame, DE bearing or retainer plate, remove the drive end (DE) frame and rotor assembly, by removing the (4) thru-bolts (mark end frames for reassembly) that hold the end frames together.
3. Separate the rotor and spacer, using a press, from DE frame. If replacing the **rotor**, save the spacer and dispose of rotor. Install spacer on new rotor and go to installation step 1.

NOTICE! It is recommended that the **DE & RE bearings be replaced when replacing the rotor**

4. If replacing the **DE frame** (with bearing), dispose of it and go to installation step 1.
5. If replacing **RE frame bearing**, remove components from frame that can be damaged by pressing bearings out and into the frame. See instructions in next section for removing and replacing RE components and graphic, on page 3, for correct dimensional location of bearing in the frame. Go to installation step 2.
6. If replacing the **DE bearing**, remove the four (4) screw assemblies and bearing retainer plate. Using a press, remove and dispose of the old bearing and press new bearing into frame bore until seated, by applying force against the outer race only.
7. Reinstall or replace bearing retainer plate. Install and torque the four (4) retainer screw assemblies to **4.5 - 5.7 Nm (40 - 50 lb in)**. Go to installation step 1.

INSTALLATION INSTRUCTIONS

1. Install rotor with spacer into DE frame, using a press.
2. Assemble the DE and RE frames, being sure to line up the non-threaded mounting lugs or marks. This is best accomplished by inserting a tolerance pin in the non-threaded holes on hinge mount (J180) units or 2 parallel blocks with pad mount units.
3. Install the four (4) thru bolts and torque to 50% of final value. Use a staggered sequence to finish and torque thru bolts to **10.7 - 11.9 Nm (95 - 105 lb)**.
4. Reinstall RE cover and four (4) mounting screw assemblies. Torque screw assemblies to **5.7 - 6.8 Nm (50 - 60 lb in)**.
5. Install external fan, pulley and pulley nut. Torque pulley nut to **95-108 Nm (70-80 lb ft)**.
6. Reinstall alternator as noted in engine or vehicle manufacturer’s instructions. See note at end of parts assembly, page 2.

REMOVAL AND INSTALLATION INSTRUCTIONS FOR RE COVER - CAPACITOR - TERMINAL PACKAGES - DIODE TRIO - REGULATOR – RECTIFIER BRIDGE – STATOR - FIELD COIL & SUPPORT - RE FRAME

REFERENCE: There is an exploded parts view of these alternators for easy reference on page 3. More detailed exploded views can be found on the www.delcoremy.com web site under product support and service parts.

33SI, 34SI, 35SI & 36SI
RECTIFIER BRIDGE

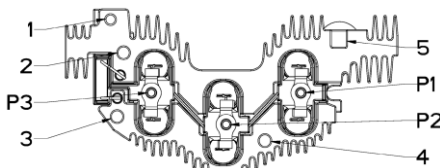

33SI, 34SI, 35SI & 36SI
VOLTAGE REGULATOR

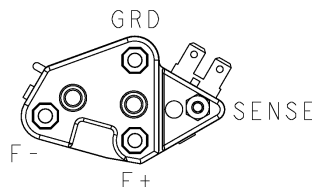

33SI & 36SI RECTIFIER BRIDGE
(FOR INSULATED MODELS)

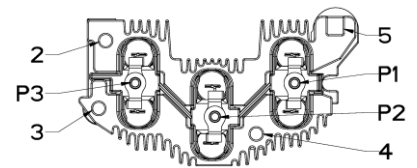

NOTE: The rectifiers are different for negative ground and insulated models and connections are different.

The regulator and rectifier terminals are labeled to enable following instructions for replacing components and parts.

NOTICE - Only licensed Remy International, Inc. product and component parts should be used, and the use of other parts or modifications not approved by Remy International, Inc. will void all applicable warranties. The failure to carefully follow these Installation Instructions, set forth above, will void all applicable warranties. DELCO REMY is a registered trademark of General Motors Corporation, licensed to Remy International, Inc. Pendleton, IN 46064.

NOTE: When referring to insulated models, the comments are underlined>. Due to the complexity of the connections to the regulator, replacement instructions below are separated for clarity.

1. Remove the RE cover to replace any of the **terminal assemblies**. It is important to note stack up of the individual parts on the terminals prior to disassembly. All terminals are insulated from the RE frame.

DANGER!!! If all terminals are not kept insulated from the frame when the battery is connected, they can quickly get hot enough to burn skin and damage surrounding parts.

2. It is advisable to remove and replace terminals one at a time, carefully noting parts stack up and where the straps and or leads are connected. Torque requirements for the R, I & Sense terminals nuts are **1.7 - 2.8 Nm (15 - 20 lb in)**. The output (B+) terminal torque is as follows: 1/4" is **5.7 - 6.8 Nm (50 - 60 lb in)** M6 is **6.8 - 9.0 Nm (60 - 80 lb in)** 5/16" is **7.4 - 11.1 Nm (65 - 98 lb in)**.

DANGER!!! **Incorrectly connecting the capacitor leads to the rectifier could result in damage or injury.**

3. If replacing the **capacitor** (insulated models only), noting orientation, remove capacitor and replace as removed. Install and torque bracket screw to **2.7 - 3.4 Nm (24 - 30 lb in)** and numbers two (2) and three (3) terminals to **2.7 - 3.4 Nm (24 - 30 lb in)**.

WARNING!!! MULTIPLE STYLES OF SCREW ASSEMBLIES ARE USED INCLUDING INSULATED AND NON-INSULATED SCREW ASSEMBLIES FOR REGULATORS AND RECTIFIER BRIDGES. THE SCREW ASSEMBLIES **MUST** BE REPLACED IN THE **SAME** LOCATION AS REMOVED TO AVOID GROUNDING OR OTHER UNDESIREABLE RESULTS.

4. If replacing the **regulator**, remove the nut and all three (3) screw assemblies, carefully noting where leads and straps are connected. The connections are as follows: **F-** [One (1) lead from field coil connected] **GRD** [Nothing is connected] **F+** [One (1) strap from P1 terminal, one (1) strap from "I" terminal and one (1) field coil lead are connected] **Sense** [one (1) lead from remote sense terminal. It's important to note if there are other straps or leads connected here because some models have a strap or lead connected to #5 rectifier terminal].

REGULATOR TERMINAL CONNECTIONS FOR INSULATED MODELS

Remove the nut and all three (3) screw assemblies, carefully noting where leads and straps are connected. The connections are as follows:

F- [One (1) field coil lead connected]

GRD (-) [One (1) lead from NEG (-) terminal connected. **NOTE:** There is also a lead (1) from the NEG (-) terminal connected to the #4 rectifier terminal]

F+ [Some models have one (1) field coil lead, one (1) diode trio strap and one (1) remote sense terminal strap connected. Other models do not have the remote sense connected here]

SENSE [Some models have a strap from #5 rectifier terminal. Other models have a lead from the remote sense terminal. **NOTE:** When there is a remote sense lead connected, there is also one (1) lead from the remote sense terminal connected to the # 4 bridge terminal]

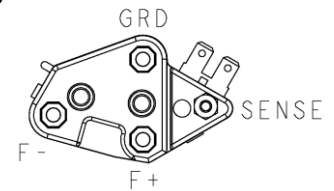

5. Install new regulator and reconnect leads and straps as removed. Install and torque the three (3) screw assemblies to **1.8 - 2.3 Nm (16 - 20 lb in)** and the nut assembly to **1.7 - 2.8 Nm (15 - 25 lb in)**.
6. If replacing the **diode trio**, remove nut assemblies from P1 (R terminal lead is connected only on insulated models), P2, P3 (R terminal strap is connected) and diode trio strap is connected to regulator F+ terminal. Also, note how the three (3) stator leads connect to the P terminals. If replacing the **stator** and or **field coil & support** go to step 8 or 9.
7. Install new diode trio, stator leads and R-terminal strap. Be sure stator leads are all the way down on the bridge. Reinstall the three (3) nut assemblies and torque to **1.7 - 2.8 Nm (15 - 25 lb in)** and the strap to F+ terminal to **1.8 - 2.3 Nm (16 - 20 lb in)**.
8. If replacing the **rectifier assembly**, remove the rest of the terminals. **1** (POS terminal strap is connected. Torque screw assembly to **1.8 - 2.3 Nm (16 - 20 lb in)**. **2** (insulated models have POS terminal strap and capacitor lead connected) **3** (insulated models have capacitor lead connected) **4** (insulated models have regulator GRD lead connected) **5** (carefully note what is or is not connected between this and the regulator sense terminal because there several combinations).
9. If replacing the **stator assembly**, remove and dispose of stator assembly and install the new one, insuring the insulator is properly placed in the slot. Go to installation step 1.
10. If replacing the **field coil & support**, remove the rectifier assembly and leads connected to the regulator. Remove the four (4) mounting bolts and dispose of the coil assembly.
11. Install the new field coil and mounting bolts. Use a staggered pattern and torque the four (4) mounting bolts to **5.7 - 6.8 Nm (50 - 60 lb in)**. Reconnect leads to GRD & F- regulator terminals and torque to values noted in step 5. Go to installation step 1.

INSTALLATION INSTRUCTIONS

1. Replace or install new rectifier assembly and replace all straps and connectors as removed. See above steps for terminations and torque requirements.
2. Assemble the DE and RE frames, being sure to line up the non-threaded mounting lugs or marks. This is best accomplished by inserting a tolerance pin in the non-threaded holes on hinge mount (J180) units or 2 parallel blocks with pad mount units.
3. Install the four (4) thru bolts and torque to 50% of final value. Use a staggered sequence to finish and torque thru-bolts to **10.7 - 11.9 Nm (95 - 105 lb)**.

REINSTALL THE ALTERNATOR ACCORDING TO ENGINE OR VEHICLE MANUFACTURERS INSTRUCTION'S

- ◆ Reattach the battery (+) terminal lead to alternator battery terminal and torque nut to **9.0-13.0 Nm (80 - 120 lb in)**.
- ◆ Reconnect the negative (-) cable at the battery.

Technical support: USA 800 854 0076, Mexico 01 800 000 7378, Brazil 0800 703 3526, South America 55 11 2106 6510 or visit delcoremy.com

NOTICE - Only licensed Remy International, Inc. product and component parts should be used, and the use of other parts or modifications not approved by Remy International, Inc. will void all applicable warranties. The failure to carefully follow these Installation Instructions, set forth above, will void all applicable warranties. DELCO REMY is a registered trademark of General Motors Corporation, licensed to Remy International, Inc. Pendleton, IN 46064.

33SI™, 34SI™, 35SI™ & 36SI™ SERVICE PARTS

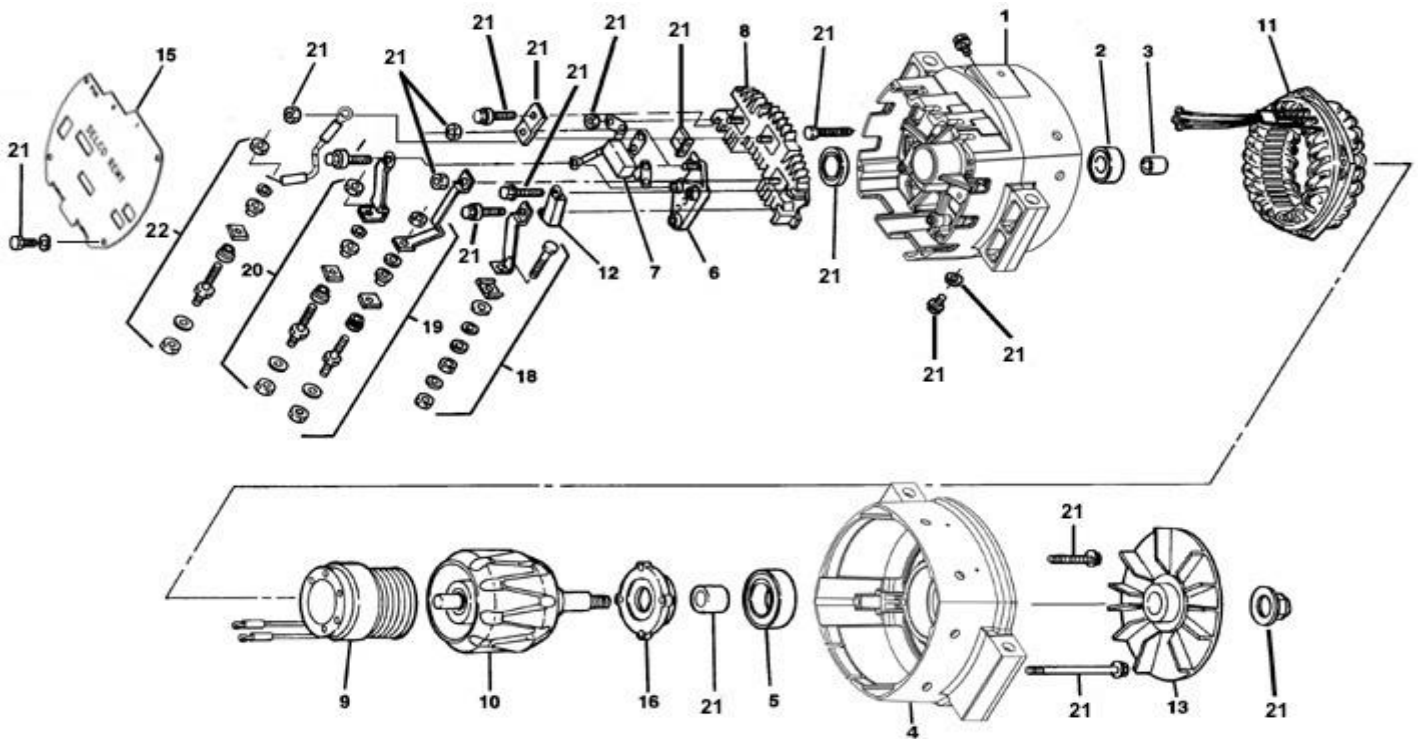

EXPLODED PARTS VIEWS OF 33SI™, 34SI™, 35SI™ & 36SI™ ALTERNATORS AND OTHER PRODUCTS ARE USUALLY AVAILABLE ON THE www.delcoremy.com WEB UNDER THE SERVICE PARTS LIST

NOTE: It is beneficial and possibly necessary to obtain the hardware package for reassembly of the alternator. It is preferable to use new, undamaged parts.

33SI, 34SI, 35SI & 36SI SERVICE PARTS PACKAGES

1. RE FRAME W / Bearing
2. ROLLER BEARING ASSEMBLY
3. RACE - ROLLER BEARING
4. DE FRAME W/ BEARING
5. BALL BEARING
6. REGULATOR
7. DIODE TRIO
8. RECTIFIER BRIDGE
9. FIELD COIL & SUPPORT ASSEMBLY
10. ROTOR ASSEMBLY
11. STATOR ASSEMBLY
12. CAPACITOR
13. FAN
15. RE COVER
16. BEARING RETAINER
18. BATTERY TERMINAL
19. RELAY
20. INDICATOR TERMINAL
21. HARDWARE REPAIR
22. SENSE TERMINAL .
- * 23. NEGATIVE BATTERY TERMINAL
- * 24. PULLY
- * 25. NUT FLANGE
- * 26. BUSHING OR RACE-BEARING (* NOT SHOWN)

RE BEARING
LOCATION

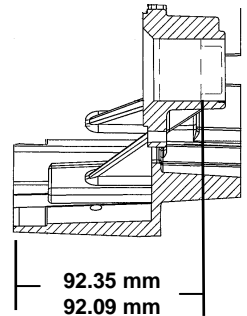

Technical support: USA 800 854 0076, Mexico 01 800 000 7378, Brazil 0800 703 3526, South America 55 11 2106 6510 or visit delcoremy.com

NOTICE - Only licensed Remy International, Inc. product and component parts should be used, and the use of other parts or modifications not approved by Remy International, Inc. will void all applicable warranties. The failure to carefully follow these Installation Instructions, set forth above, will void all applicable warranties. DELCO REMY is a registered trademark of General Motors Corporation, licensed to Remy International, Inc. Pendleton, IN 46064.
© 2012 Remy International, Inc. All rights reserved