

SERVICING THE SLIP RING END FRAME ON 27SI SERIES, 200 TYPE ALTERNATORS

WARNING!!! ALWAYS USE PROPER EYE PROTECTION WHEN PERFORMING ANY MECHANICAL REPAIRS TO A VEHICLE – INCLUDING, BUT NOT LIMITED TO, ANY INSTALLATION AND OR REPAIRS TO THE DELCO REMY ALTERNATOR. FAILURE TO USE PROPER EYE PROTECTION CAN LEAD TO SERIOUS AND PERMANENT EYE DAMAGE.

Only perform the mechanical functions that you are properly qualified to perform. Mechanical repairs that are beyond your technical capabilities should be handled by a professional installation specialist.

DANGER!!! To avoid injury or damage, always disconnect the negative cable at the battery before removing or replacing the alternator. The alternator output terminal is always live (“hot”). If the battery is not disconnected, a tool accidentally touching this terminal and ground can quickly get hot enough to cause skin burn or damage to the tool and surrounding parts.

The proper assembly of parts before attaching stator and diode trio is illustrated in Figure 1. Assemble "R" terminal connector over rectifier bridge threaded stud and then attach the stator and diode trio.

To assemble the alternator:

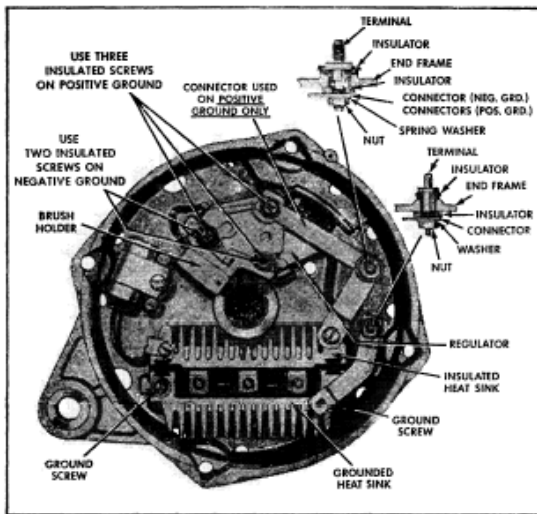

Figure 1

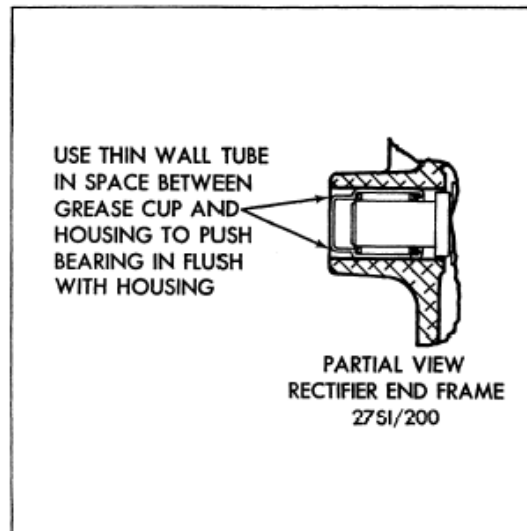

Figure 2

1. Clean brushes with soft dry cloth.
2. Insert a pin or toothpick to retain springs and brushes in holder.
3. Remove tape from shaft and from end frame.
4. Assemble drive end frame to slip ring end frame.
5. Remove pin or toothpick.
6. Install bearing flush with housing. Carefully note Figure 2.

Technical support: USA 800 854 0076, Mexico 01 800 000 7378, Brazil 0800 703 3526, South America 55 11 2106 6510 or visit delcoremy.com

NOTICE - Only licensed Remy International, Inc. product and component parts should be used, and the use of other parts or modifications not approved by Remy International, Inc. will void all applicable warranties. The failure to carefully follow these Installation Instructions, set forth above, will void all applicable warranties. DELCO REMY is a registered trademark of General Motors Corporation, licensed to Remy International, Inc. Pendleton, IN 46064.